



PP9100 USER MANUAL

Please read these instruction carefully before using the product.

Product specification and components

Features	Basic Specification	
6 unlocking ways	User Capacity	99
Face ID	Unlocking Way	Face ID + Fingerprint + Password + Card + Mechanical Key + Application
Biometric fingerprint reader	Voice guide language	English
Bluetooth APP control	Power	Battery: 8PCS* AA Alkaline Battery
Burglary alarm function	Emergency Power	5V , USB Type-C
Random security coding	Alarming Voltage	<4.8V
Privacy function	Material	Lock panel: Aluminum Alloy, ABS+PET
Low battery alarm	Mortise Lock	Stainless Steel
Emergency power supply (USB Type-C)	Working Environment	Temperature: -20°C - 70°C
Prevent mischief and hacking	Humidity	40% - 80%
Voice prompts		

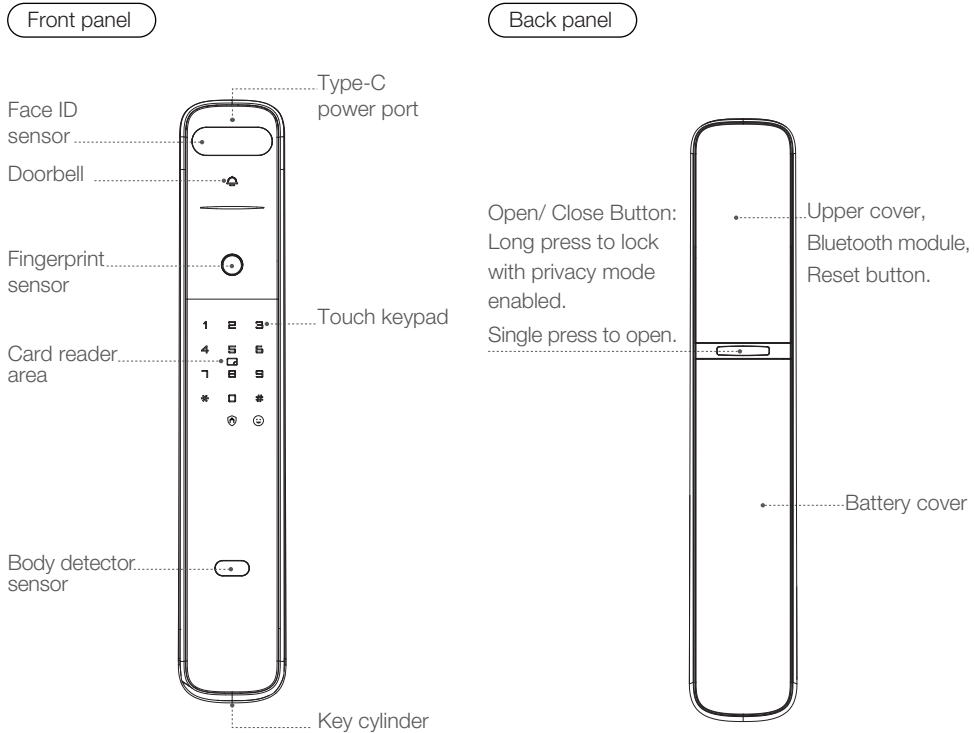

* The contents of this user manual are subject to change without prior notice to the user in order to enhance performance of the products.



- Mortise Lock
- Mechanical key
- Packing List

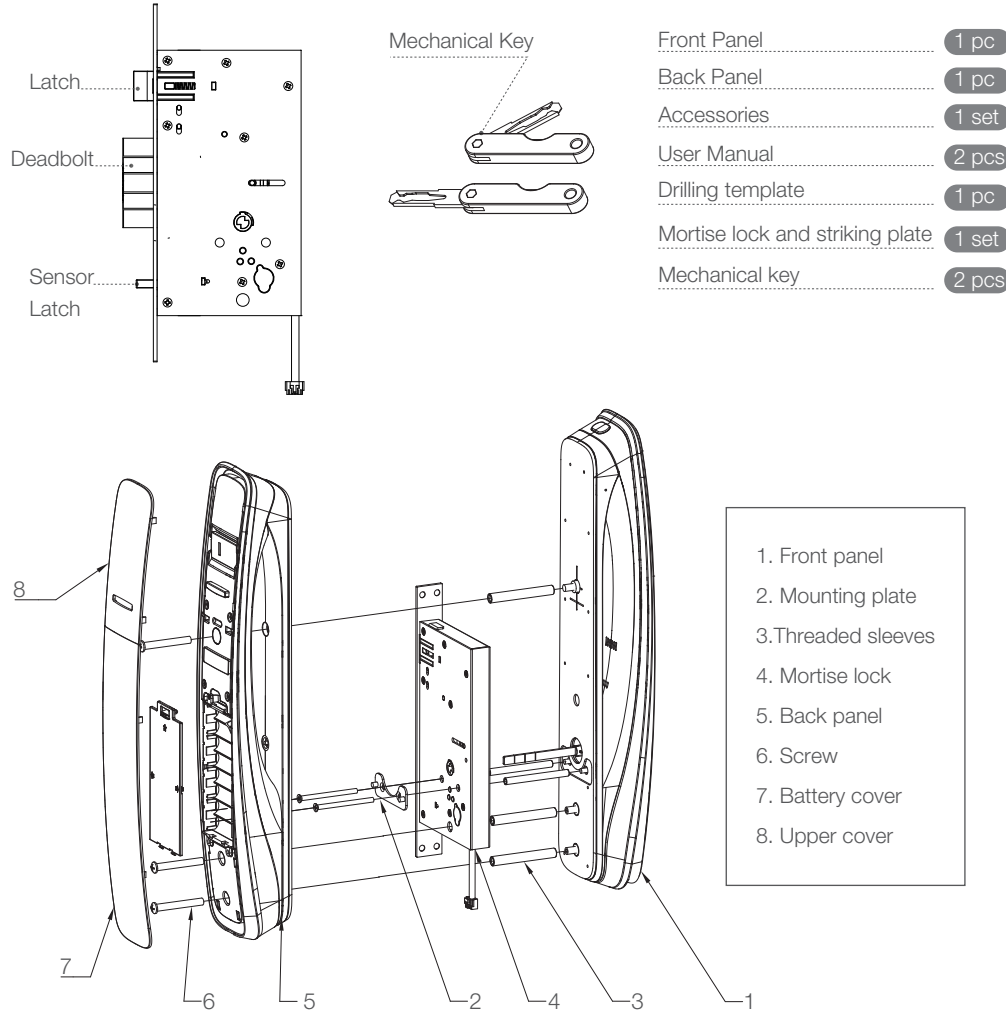

Installation steps

1 Draw lines on the door as marked on the template, the suggested distance between handle and the floor is 1m-1.2 m, Then drill the holes as required.



2 Change latch direction, disassemble the faceplate of the mortise and rotate the latch bolt 180°. Then reinstall the faceplate.

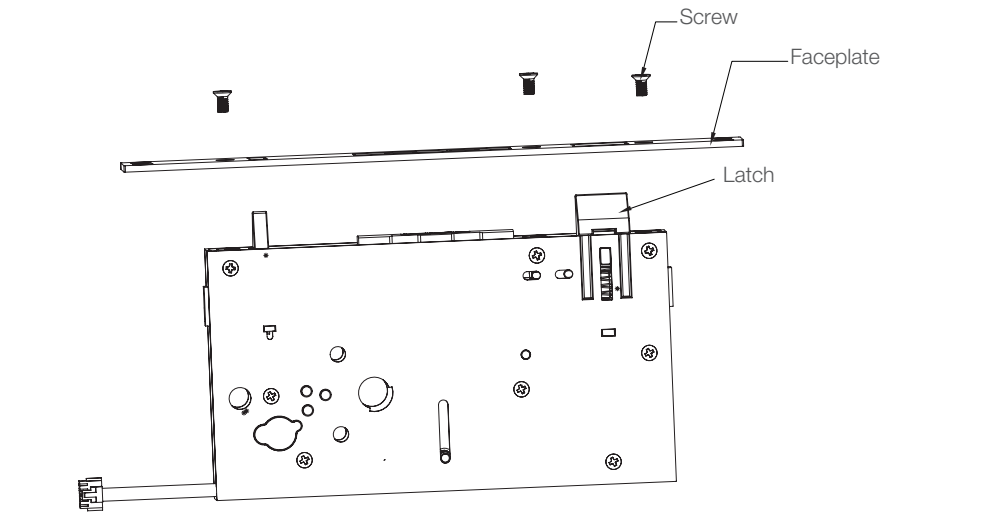

3 Insert mortise into the door and use 4 pcs of M5*10 crosshead screws to fix the mortise. (ST4.2*25 self-tapping counter sunk screws for Wooden Door).

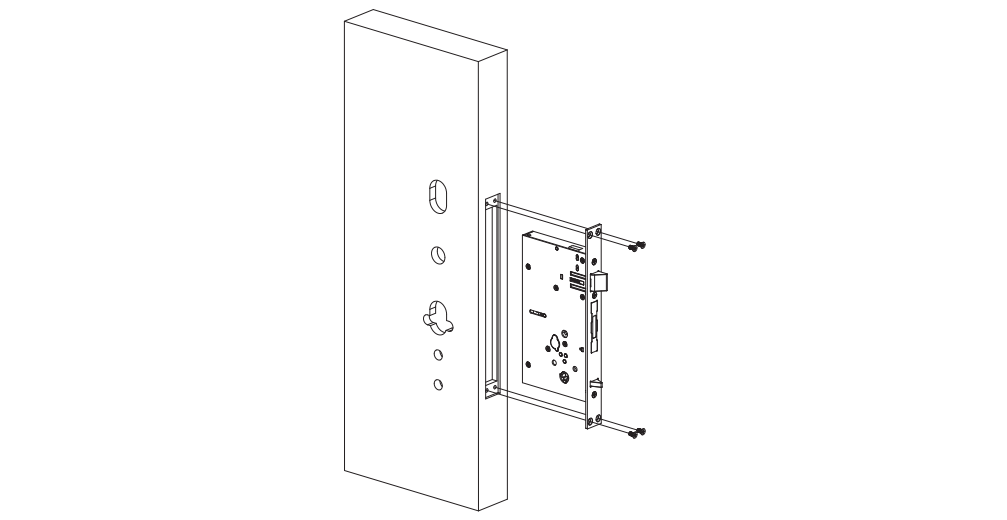

4 Install transmission rod on the front panel as shown above. Please adjust the transmission rod to the position as shown below.

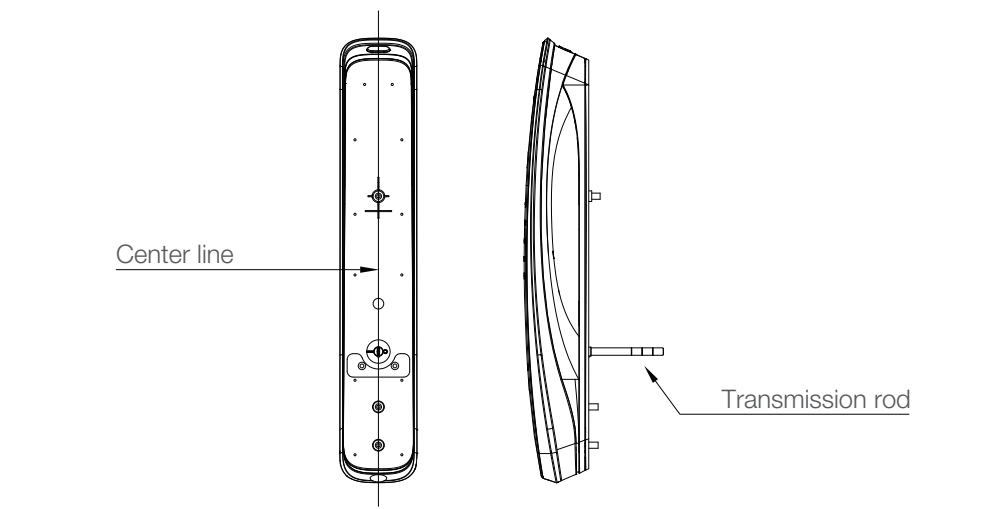

5 Install 5pcs threaded sleeves on the front panel.

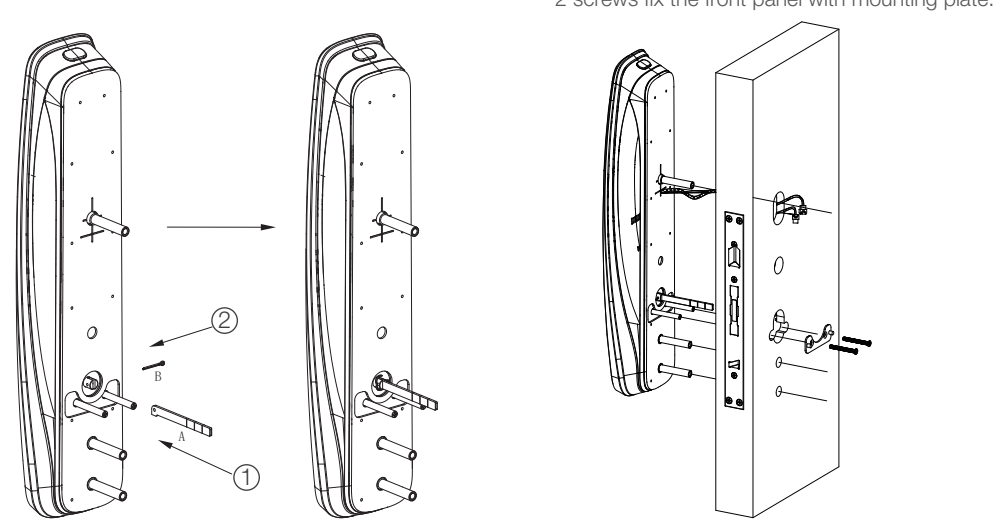

7 Connect front panel cable and mortise cable to related connectors on back panel.

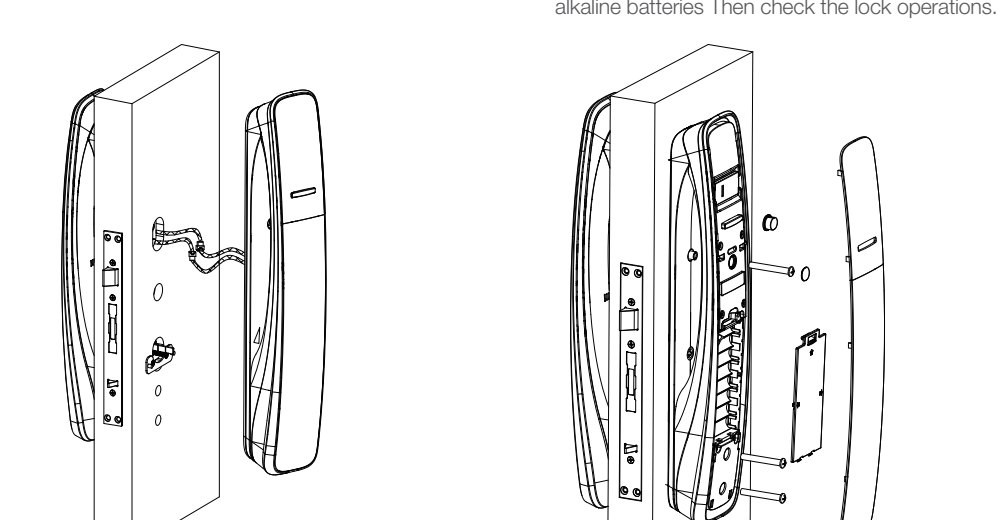

9 After finished installation, please pair front and back panel by using a paper clip and keep pressing the reset button for 6-7 seconds until you hear 2 beeps sound.

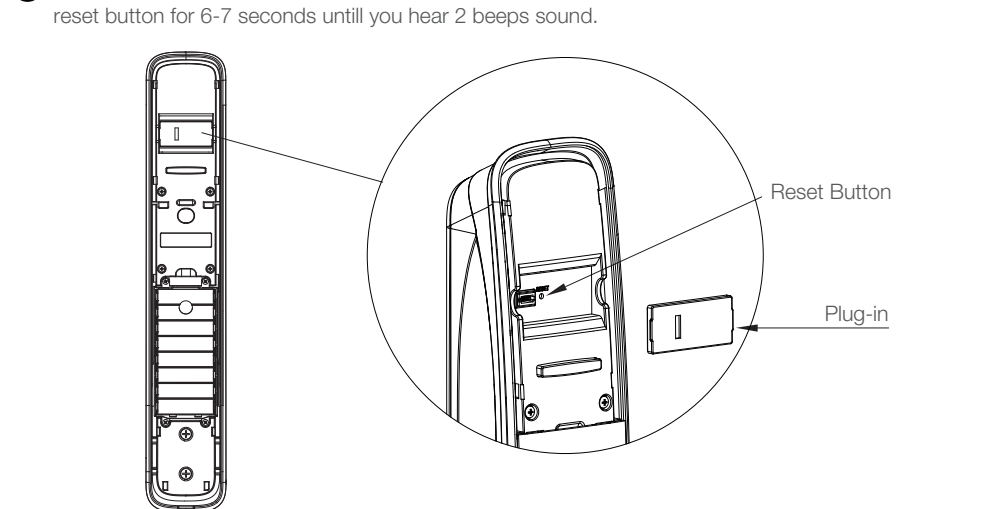

Instructions

Emergency Power Supply

When the battery voltage is too low and the lock cannot be opened from outside, connect a 5V power supply via USB Type-C port at the front. Then unlock the door and replace all batteries immediately.

Restore default settings

Remove the upper cover and take out Bluetooth module. Then use a paper clip and keep pressing the reset button for 3 sec until you hear 1 beep sound. After that all user data and settings will be deleted.

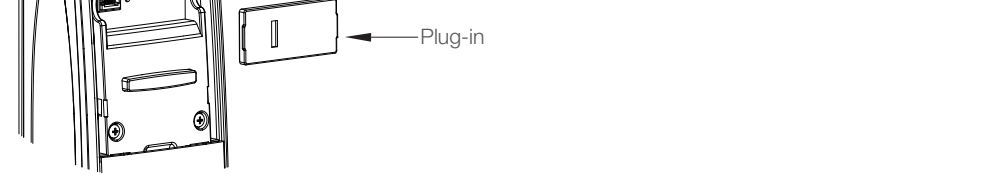

Keypad operation instructions

NOTE: # = ⌘, * = ⌘

- Exit and delete
- Mute mode (Press this button twice)

Indicator Meaning

Lock status indicator
The light flashes green when verification succeeded. The light flashes red when verification failed.

Low battery status indicator
Light flashes red when battery is low with voice prompts (non-mute mode).

System locked status indicator
If enter wrong user ID 5 times in 5 minutes, lock will suspend 90 seconds with alarm and indicator turns red.

Mute mode indicator
The indicator of turn on/turn off mute mode is green with voice prompts (double click * key to turn on/ turn off mute mode).

Privacy mode indicator
After turn on privacy mode, the indicator light is red when the system is woke up. When press #, the light will turn blue only admin fingerprint/ password able to unlock in this mode.

Restore factory settings indicator
The indicator light is green when the system data is cleared.



Defense mode indicator
The light flashes green when defense mode enabled.

Bluetooth Indicator
The indicator light is blue when Bluetooth is pairing.
The indicator light is green when pairing succeeded.
The indicator light is red when pairing failed.

Face recognition indicator
The indicator light is blue after pressing the face ID button on the front panel.

How to lock/ unlock the door

Lock the door
The door will be locked automatically after closing. (Auto lock)
Note: This lock has no manual lock function.

Unlock from outside
Face ID: Touch the keypad to wake up the lock and press the Face ID button to activate the sensor.
If automatic face ID function is enabled, just stand 30-50 cm in front of the lock and face sensor will automatically unlock the door.

Fingerprint: Place the enrolled fingerprint on the sensor.
Key card: Touch the keypad to wake up the lock and tap the enrolled key card on the reader area.
PIN code: Touch the keypad to wake up the lock and input 6-8 digits PIN code then press # to confirm.

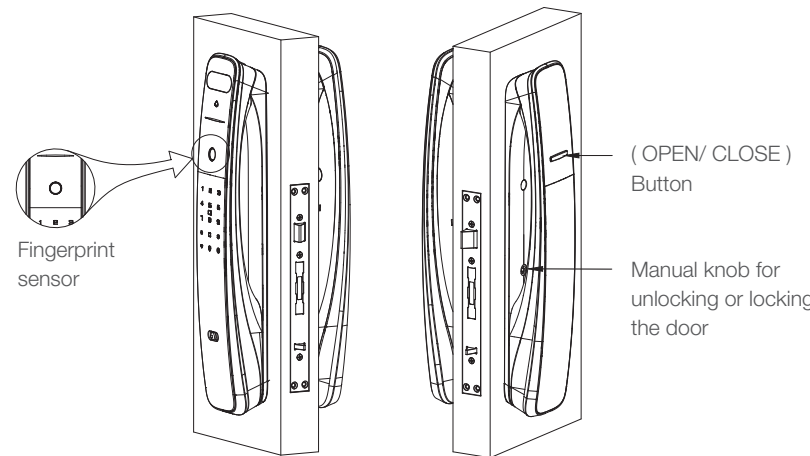

Lock / Unlock from inside
1. Short press (OPEN/ CLOSE) button on back panel, which will quickly unlock and when the button light turns green.
2. Long press (OPEN/ CLOSE) button on back panel 3 seconds to lock the door and enable privacy mode, the button light will turn from green to red.
3. Lock/ Unlock the door in emergency by rotating the knob on the back panel.

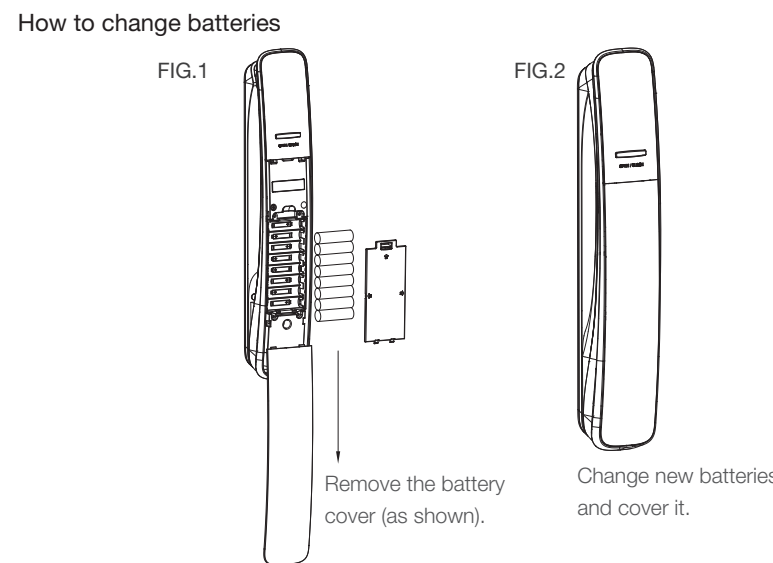

Operating process

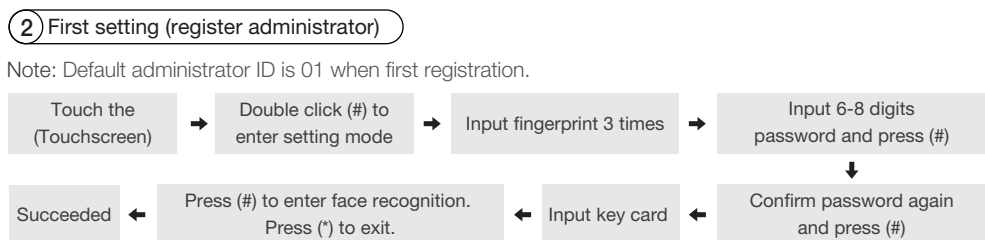
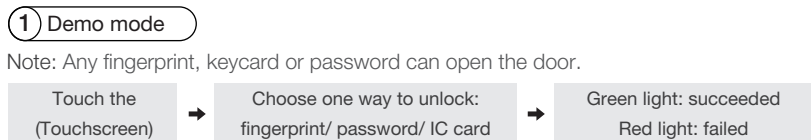

Face recognition function
Note: • The smart lock must be equipped with eight batteries before using the face ID function.
• Make sure no one is behind you when you register your face, otherwise, face ID registration may fail.
• Make sure you paired front and back panel following No.9 step of installation step before registering Face ID.
• Face ID function consumes more power. It may reduce battery life time depends on operating frequently.
• Applicable Height: 1.4m - 2m.
• Recognition distance: 0.3m - 1m.
• Recognition speed: < 1.3s.
• Face recognition angle: Pitch angle: 30°, Rotation angle: 30°, Yaw angle: 30°.
• User capacity: 99.

Follow the voice prompt to register face recognition. Please use your hand to slightly block the light above the face sensor when the light is too bright.
Voice prompt:
• 2 Please move forward.
• 4 Please be left ; Move to the left side.
• 5 Please keep / Please look up/ Please look down/ Turn your head to the left/ Turn your head to the right/Excessive light.
• 6 Please be right ; Move to the right side.
• 8 Please move backward.

Operation: Please stand at an appropriate distance and face to the camera, then touch the screen and press the face ID button key to verify.

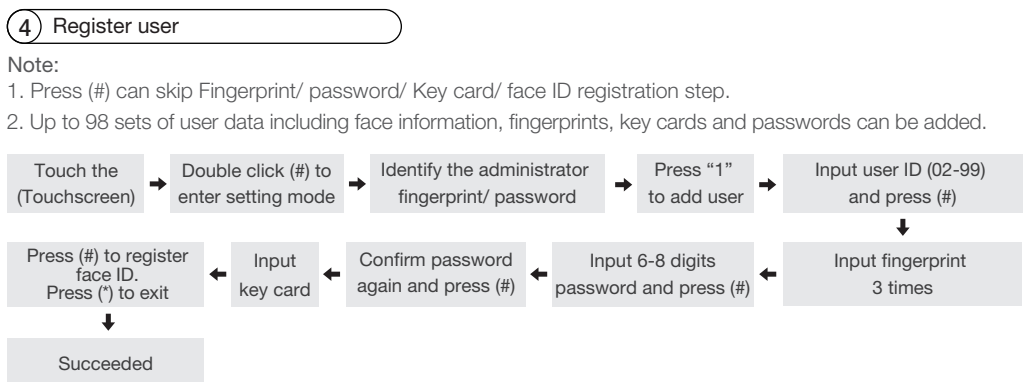
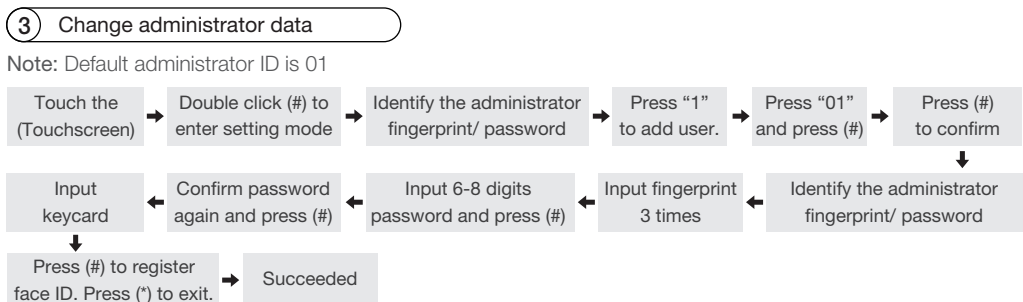

Delete registered user
Note: Input 01 will prompt deletion failure. When the battery power is low, the face recognition function will turn off and the face information cannot be deleted.

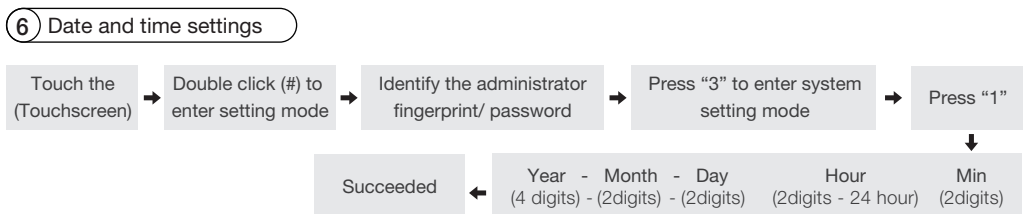
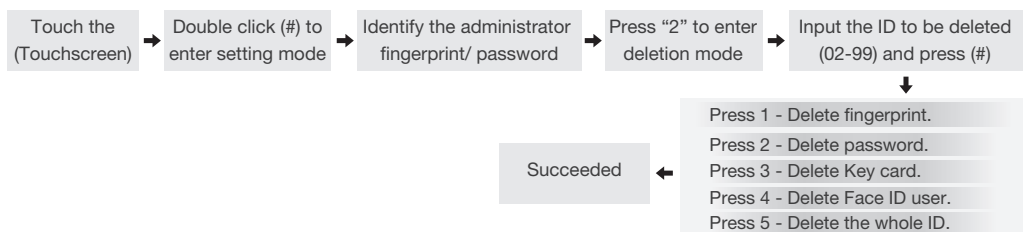

For example: If the current date and time is 2 Feb 2023 @ 5:23 pm, Date format is 2023-02-02 and time format is 17-23.

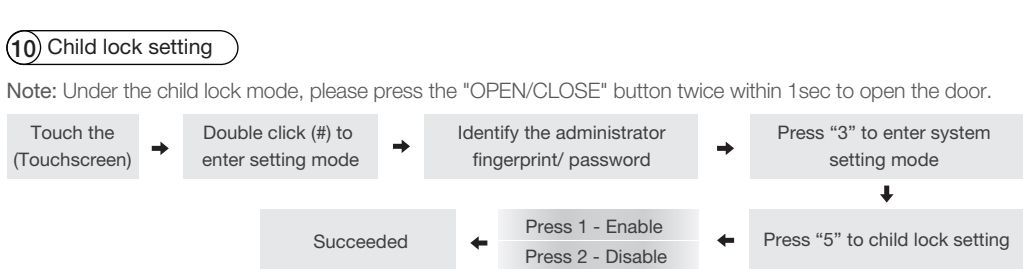
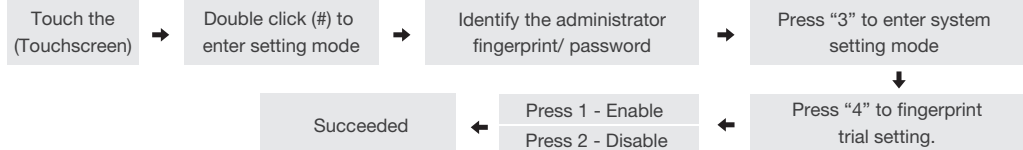
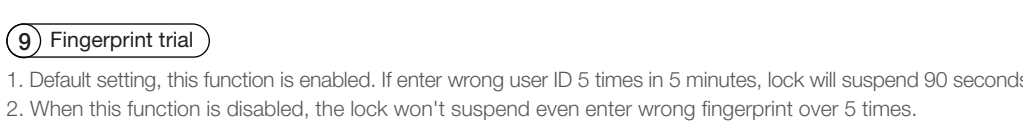
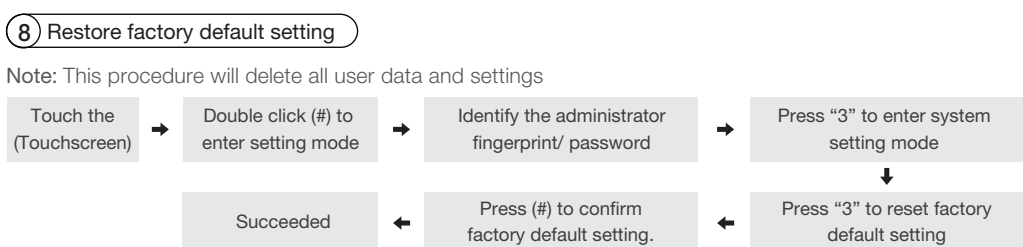
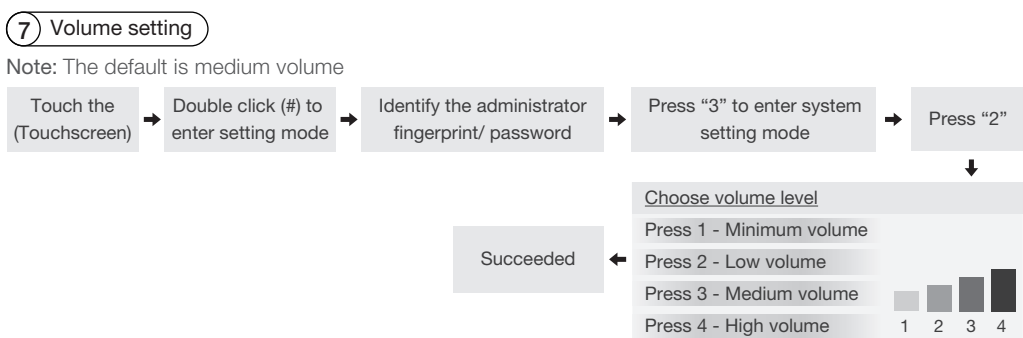

Bluetooth Pairing
First step please download Hafele Smart Living App from the App store or Play store before using this function. Then finish the signing up process.

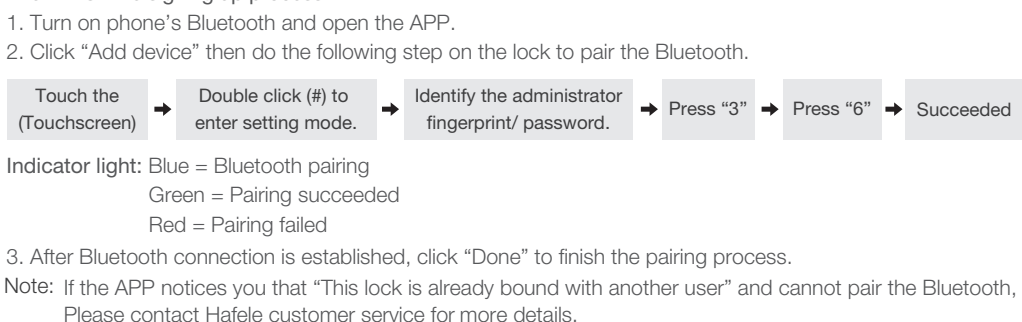

Automatic Face ID function - Body detector sensor ON/ OFF
Note: 1. Default setting, this function is disabled.
2. When someone approaches in front of the lock within distance 30-50cm, the face ID function will be activated automatically. However, enabling the automatic face detection function will shorten the battery life if someone walks past the lock frequently. Check the battery level regularly.

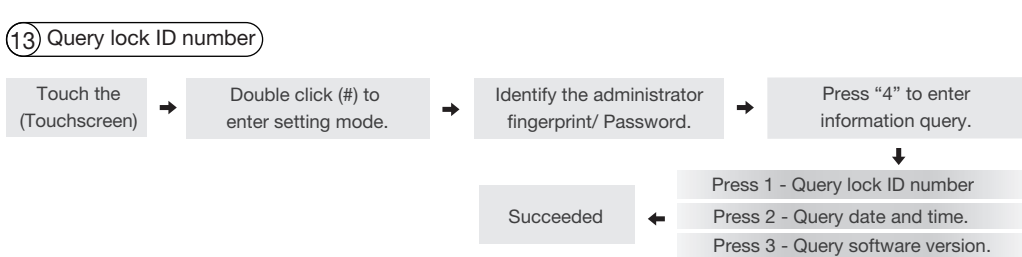

Operation Features

Type of user ID
1. Administrator (01) can open the door and manage lock data information. In special cases, the administrator user has the highest authority. We recommend only the households and leadership to use this level function.
2. Common user (02-99) can open the door only.

Key function
1. " * " Exit key and delete key, " # " enter key.
2. Double click " # " key to setting mode.
3. Double click " * " key to mute mode, and once double click " * " can exit mute mode. In mute mode, double-click the " # " key to enter the setting mode and with voice guidance. Automatically switch to mute mode after exiting setting mode.
4. " 🛡️ " Defense button: When the door is locked, long press the defense button. Lock will sound an alarm when someone opens the door from inside. You can verify an enrolled fingerprint/ key card / password to turn off an alarm.
5. " 🔔 " Doorbell key.
6. " 🗨️ " Face recognition.

Privacy mode
Long press (OPEN/ CLOSE) button inside the door to enable this function. When privacy mode is ON, only the administrator fingerprint and password can open from the outside. Common user cannot unlock the door in this mode.



System reset function
Please keep pressing the reset button on the back panel with a paper clip for at least 3 seconds to restore the lock to factory default. This procedure will delete all user data and settings.

Random security coding function
Add any numbers before or behind the real user PIN code but the maximum length is 18 digits. This feature will prevent the real user PIN code from being exposed.

Emergency power supply
When the battery voltage is too low and cannot be opened from outside, connect 5V power supply via Type-C USB cable at the front. Then unlock the door and replace all batteries immediately.

Low power alarm
When the voltage is lower than 4.8V, there will be a sound alarm after each opening, Please replace all batteries immediately.

Burglar alarm
1. If someone tries to break in, the lock will sound an alarm.
2. To turn off the alarm: Touch the keypad and identify with the authorized ID.

Prevent mischief and hacking
If enter wrong user ID 5 times in 5 minutes, lock will suspend 90 seconds with alarming, after that the lock will activate again.

System reboot function
If the lock system is not working, please use Type-C USB cable to connect to portable power bank and plug in emergency power supply interface.

The front and back panels are unmatched
Please press the reset button 6-7 seconds until you hear 2 beeps sound when the system prompts " please press reset button " to pair front panel and back panel (No data is deleted).

Caution

- Read and understand all instructions before use.
- If damage is caused by failure to follow these instructions, the warranty does not apply.
- Only use the alkaline batteries. And it is not recommended to use special battery such as EVOLTA, etc.
- Do not expose the product and accessories to rain or water.
- Do not expose the product to corrosive substances to avoid damage to the protective cover.
- Do not scrape the fingerprint sensor with any sharp objects, otherwise it may cause permanent damage.
- When cleaning the product, please wipe with a soft cloth.
- If there is a low battery alert, please replace all the batteries in time and make sure they are properly installed.